



MODEL NO. : TM020GDH03

ISSUED DATE: 2008-12-09



VERSION : Ver 1.0

- Preliminary Specification
- Final Product Specification

Customer : _____

Approved by	Notes

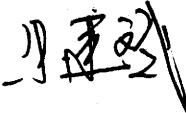
SHANGHAI TIANMA Confirmed :

Prepared by	Checked by	Approved by
 2008.12.09	 2008-12-10	 08/12/10

This technical specification is subjected to change without notice

The information contained herein is the exclusive property of SHANGHAI TIANMA MICRO-ELECTRONICS Corporation, and shall not be distributed, reproduced, or disclosed in whole or in part without prior written permission of SHANGHAI TIANMA MICRO-ELECTRONICS Corporation.



Table of Contents

Coversheet.....	1
Record of Revision.....	3
1 General Specifications	4
2 Input/Output Terminals	5
3 Absolute Maximum Ratings.....	7
4 Electrical Characteristics	8
5 Timing Chart.....	10
6 Optical Characteristics	16
7 Environmental / Reliability Test.....	20
8 Mechanical Drawing	21
9 Packing Drawing	22
10 Precautions For Use of LCD Modules.....	23



Record of Revision

Rev	Issued Date	Description	Editor
1.0	2008-12-09	Preliminary Release	Jianbin Zhu



1 General Specifications

	Feature	Spec
Display Spec	Size	2.0 inch
	Resolution	176(RGB) x 220
	Interface	CPU 16 /8 Bits
	Color Depth	262K/65K
	Technology Type	a-Si
	Pixel Pitch (mm)	0.180x0.180
	Pixel Configuration	R.G.B. Vertical Stripe
	Display Mode	TM With Normally White
	Surface Treatment(Up Polarizer)	Clear Type (3H)
	Viewing Direction	6 o'clock
	Gray Scale Inversion Direction	12 o'clock
Mechanical Characteristics	LCM (W x H x D) (mm)	38.03 x 51.65x2.50
	Active Area(mm)	31.68x39.60
	With /Without TSP	Without TSP
	Weight (g)	8.15
	LED Numbers	3 LEDs
Electronic	Driver IC	HX8340-B

Note 1: Viewing direction for best image quality is different from TFT definition, there is a 180 degree shift.

Note 2: Requirements on Environmental Protection: RoHS

Note 3: LCM weight tolerance: +/- 5%



2 Input/Output Terminals

2.1 TFT LCD Panel

No	Symbol	I/O/P	Description	Remark
1	DB15	I	Data Bus	
2	DB14	I	Data Bus	
3	DB13	I	Data Bus	
4	DB12	I	Data Bus	
5	DB11	I	Data Bus	
6	DB10	I	Data Bus	
7	DB9	I	Data Bus	
8	DB8	I	Data Bus	
9	GND	P	Ground	
10	DB7	I	Data Bus	
11	DB6	I	Data Bus	
12	DB5	I	Data Bus	
13	DB4	I	Data Bus	
14	DB3	I	Data Bus	
15	DB2	I	Data Bus	
16	DB1	I	Data Bus	
17	DB0	I	Data Bus	
18	IOVCC	P	Logical I/O Power Supply	
19	VCC	P	Drive Power Supply	
20	/RD	I	Read Signal	Active Low
21	/WR	I	Write Signal	Active Low
22	RS	I	Register Select	Low Index High Register
23	/CS	I	Chip Select Signal	Active Low
24	/RESET	I	Reset Signal	Active Low
25	IM0	I	Mode Select Low: 16bits High: 8bits	
26	GND	P	Ground	
27	LED_A	P	Anode of LED	
28	LED_K1	P	Cathode of LED	



29	LED_K2	P	Cathode of LED	
30	LED_K3	P	Cathode of LED	
31	Y+	--	No Connection	
32	Y-	--	No Connection	
33	X+	--	No Connection	
34	X-	--	No Connection	
35	NC	--	No Connection	
36	NC	--	No Connection	

Note: I/O Definition:

I----Input O----Output P----Power/Ground



3 Absolute Maximum Ratings

3.1 Driving TFT LCD Panel

GND=0V, Ta = 25°C

Item	Symbol	Min	Max	Unit	Remark
Logic Supply Voltage	IOVCC	-0.3	3.6	V	
Analog Supply Voltage	VCC	-0.3	4.2	V	
Logic Input Signal Voltage	DB0~DB15, /CS RS,/WR,/RD /RESET,IM0	-0.3	IOVCC+0.5	V	
Back Light Forward Current	I _{LED}	--	25	mA	For Each LED
Operating Temperature	T _{OPR}	-20	70	°C	
Storage Temperature	T _{STG}	-30	80	°C	



4 Electrical Characteristics

4.1 Driving TFT LCD Panel

GND=0V, Ta=25°C

Item	Symbol	Min	Typ	Max	Unit	Remark	
Logic Supply Voltage	IOVCC	2.5	2.8	3.3	V		
Analog Supply Voltage	VCC	2.5	2.8	3.3	V		
Input Signal Voltage	Low Level	V_{IL}	0	--	$0.2 \times IOVCC$	V	DB0~DB15 /CS,RS,WR /RD,/RESET IM0
	High Level	V_{IH}	$0.8 \times IOVCC$	--	IOVCC	V	
Output Signal Voltage	Low Level	V_{OL}	-0.3	--	$0.2 \times IOVCC$	V	
	High Level	V_{OH}	$0.8 \times IOVCC$	--	IOVCC	V	
(Panel+ LSI) Power Consumption	Black Mode (60Hz)	--	7.85	13.50	mW		
	Sleeping Mode	--	22.5	26.5	μ W		

4.2 Driving Backlight

Ta=25°C

Item	Symbol	Min	Typ	Max	Unit	Remark
Forward Current	I_F	--	15	--	mA	For each LED
Forward Voltage	V_F	--	3.2	--	V	Note1,2,3
Power Consumption	W_{BL}	--	144	--	mW	

Note 1: The figure below shows the connection of backlight LED.

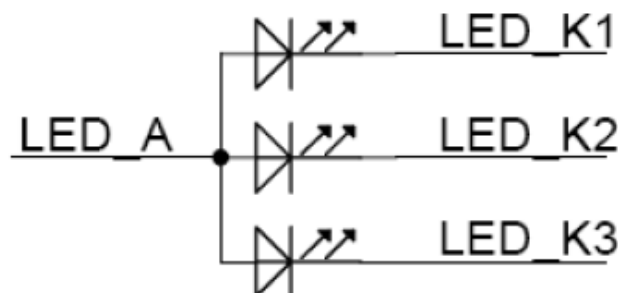

Note 2: One LED : $I_F = 15$ mA, $V_F = 3.2$ V.

Note 3: The minimal life of LED : 20,000 hours.



4.3 Block Diagram

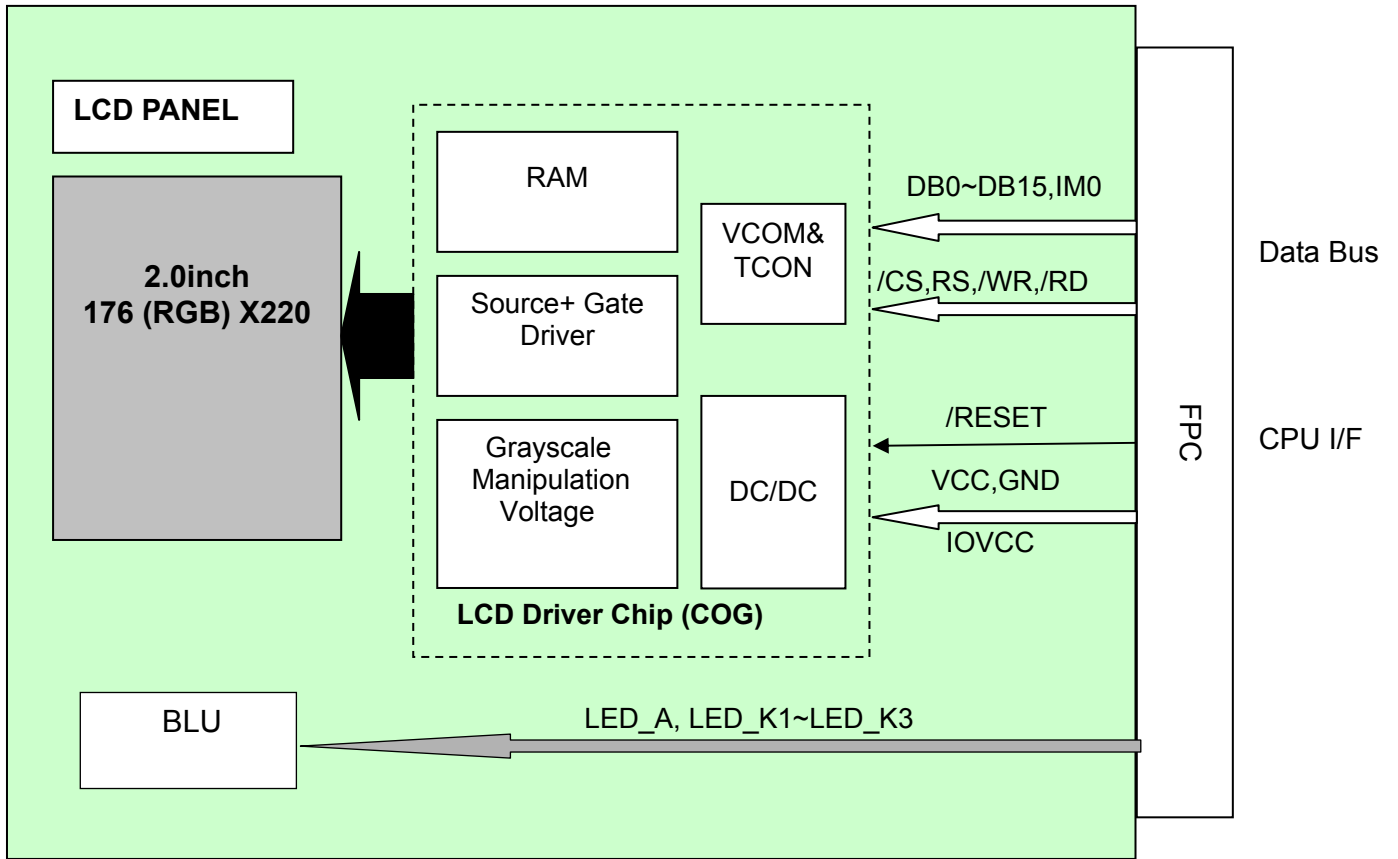



5 Timing Chart

5.1 Timing Parameter

Item	Symbol	Unit	Min	Typ	Max
Bus Cycle Time Write	t_{CYCW}	ns	66	--	--
Write Low-level Pulse Width	t_{WLW}	ns	15	--	--
Write High-level Pulse Width	t_{WHW}	ns	15	--	--
Write Rise/Fall Time	$t_{Wr,Wf}$	ns	--	--	15
Address Setup Time	t_{AS}	ns	10	--	--
Address Hold Time	t_{AH}	ns	10	--	--
Write Data Setup Time	t_{DSW}	ns	10	--	--
Write Data Hold Time	t_H	ns	10	--	--

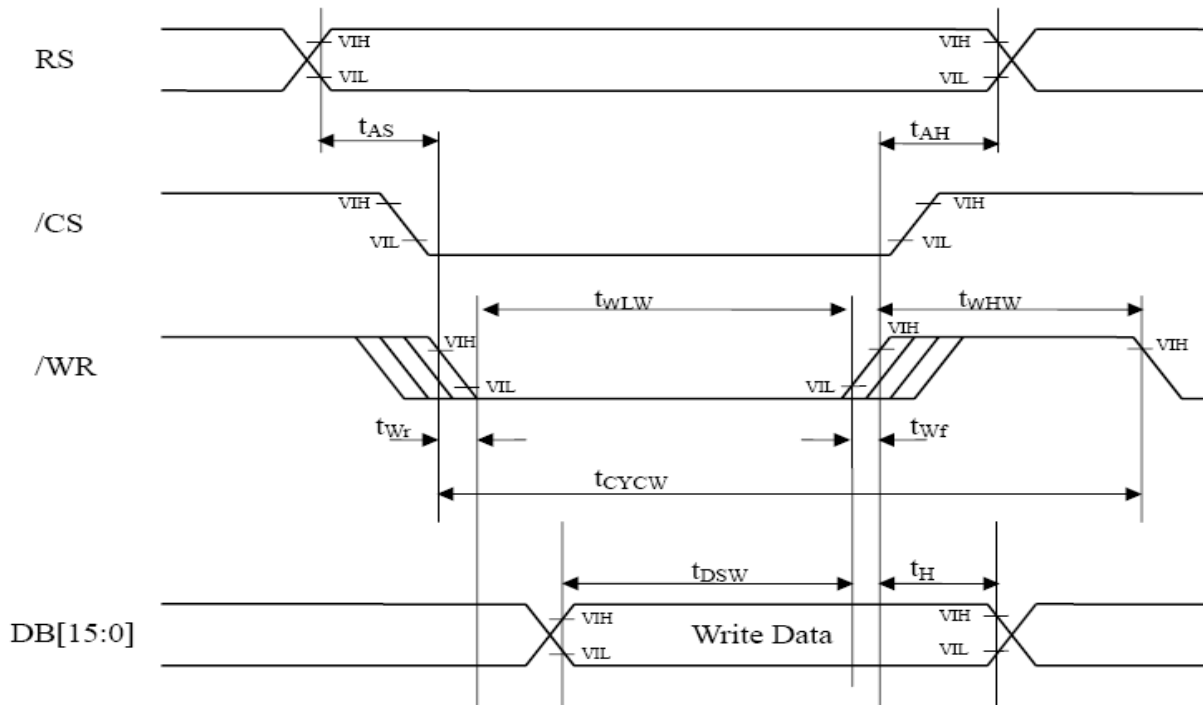

Reset timing

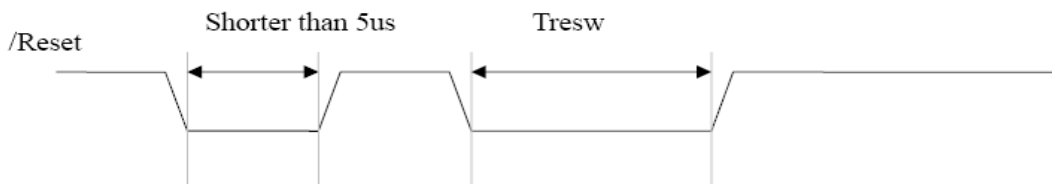

Note: T_{resw} (at least 10us)

The information contained herein is the exclusive property of SHANGHAI TIANMA MICRO-ELECTRONICS Corporation, and shall not be distributed, reproduced, or disclosed in whole or in part without prior written permission of SHANGHAI TIANMA MICRO-ELECTRONICS Corporation.



5.2 Register Write Timing

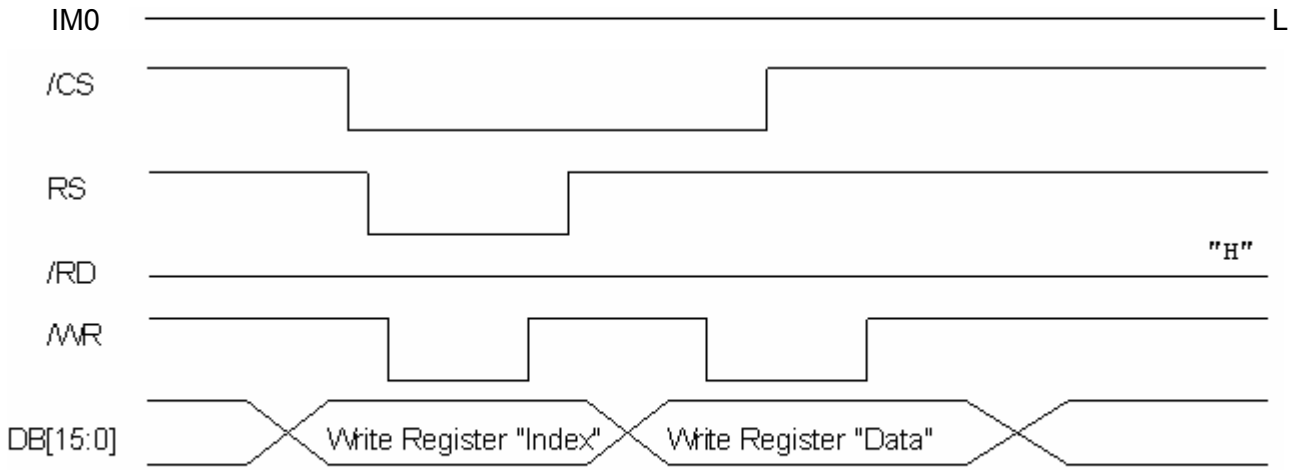

Figure 5.2.1 16-bit System Bus Interface Timing(Register Write Timing)

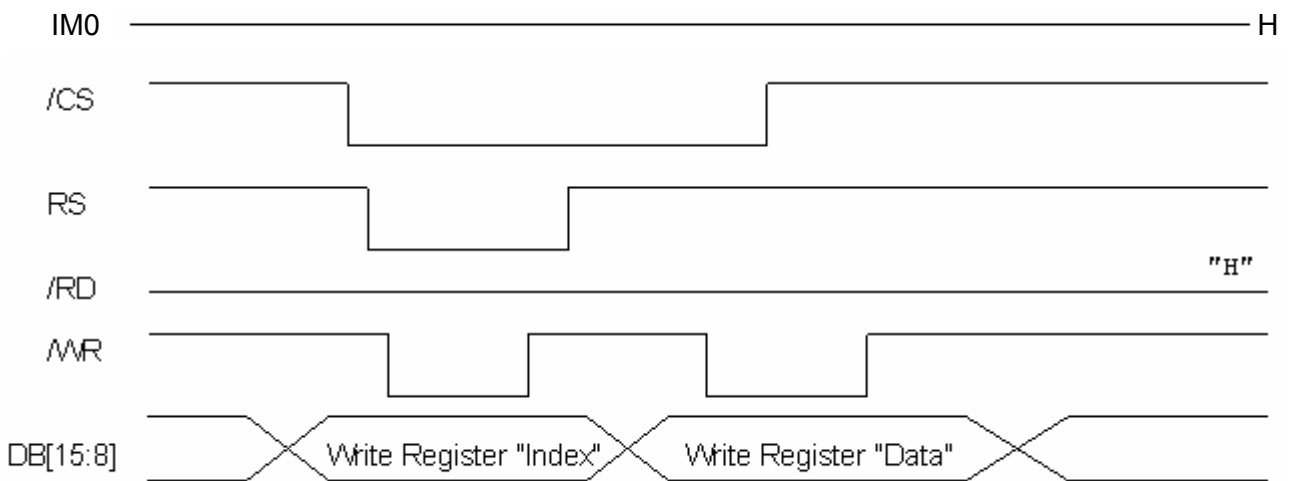

Figure 5.2.2 8-bit System Bus Interface Timing(Register Write Timing)



5.3 Gram Write/Read Timing

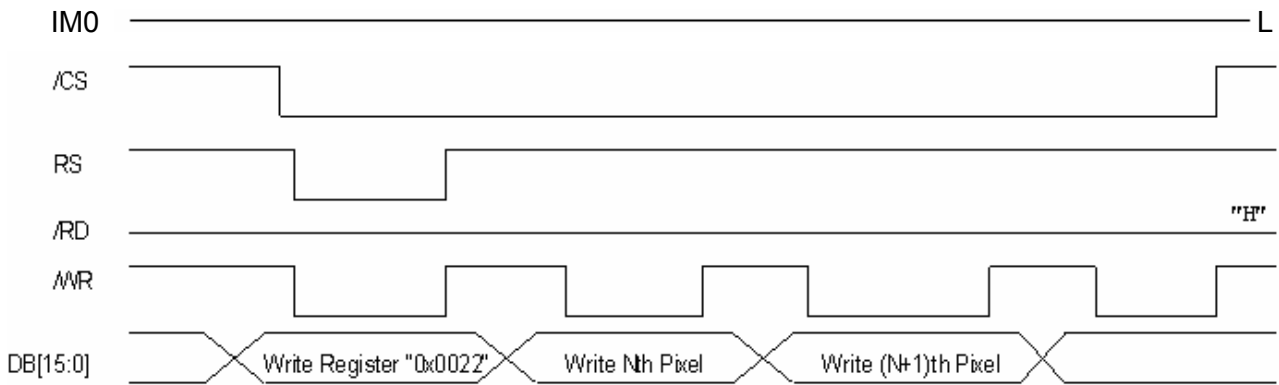

Figure 5.3.1 16-bit Write data for RGB 5-6-5-bit input (GRAM Write Timing)

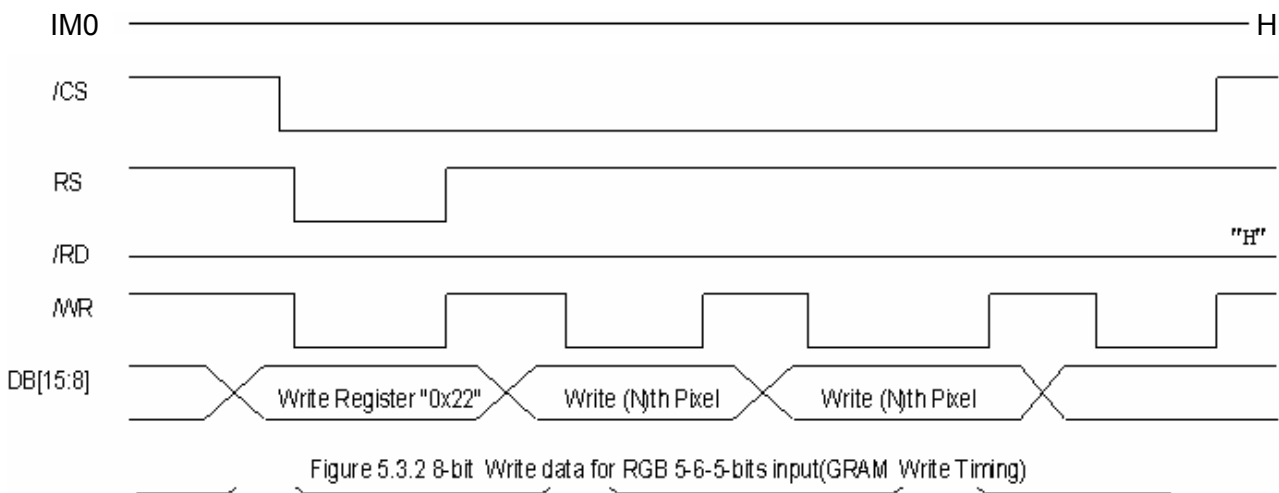

Figure 5.3.2 8-bit Write data for RGB 5-6-5-bit input (GRAM Write Timing)

Figure 5.2.2 8-bit System Bus Interface Timing (Register Write Timing)



5.4 Display Mode

5.4.1. 16-Bit Bus Gram Mode Select

Register	DB15	DB14	DB13	DB12	DB11	DB10	DB9	DB8	DB7	DB6	DB5	DB4	DB3	DB2	DB1	DB0	Command
Command	X	X	X	X	X	X	X	X	0	0	1	0	0	0	1	0	22H
17H	DB15	DB14	DB13	DB12	DB11	DB10	DB9	DB8	DB7	DB6	DB5	DB4	DB3	DB2	DB1	DB0	Color
03h	X	X	X	X	R3	R2	R1	R0	G3	G2	G1	G0	B3	B2	B1	B0	4K-Color
05h	R4	R3	R2	R1	R0	G5	G4	G3	G2	G1	G0	B4	B3	B2	B1	B0	65K-Color
06h	R5	R4	R3	R2	R1	R0	X	X	G5	G4	G3	G2	G1	G0	X	X	262K-Color
	B5	B4	B3	B2	B1	B0	X	X	R5	R4	R3	R2	R1	R0	X	X	
	G5	G4	G3	G2	G1	G0	X	X	B5	B4	B3	B2	B1	B0	X	X	

5.4.2. 8-Bit Bus Gram Mode Select

Register	DB15	DB14	DB13	DB12	DB11	DB10	DB9	DB8	DB7	DB6	DB5	DB4	DB3	DB2	DB1	DB0	Command
Command	X	X	X	X	X	X	X	X	0	0	1	0	0	0	1	0	22H
17H	DB15	DB14	DB13	DB12	DB11	DB10	DB9	DB8	DB7	DB6	DB5	DB4	DB3	DB2	DB1	DB0	Color
03h	R3	R2	R1	R0	G3	G2	G1	G0	X	X	X	X	X	X	X	X	4K-Color
	B3	B2	B1	B0	R3	R2	R1	R0									
	G3	G2	G1	G0	B3	B2	B1	B0									
05h	R4	R3	R2	R1	R0	G5	G4	G3	X	X	X	X	X	X	X	X	65K-Color
	G2	G1	G0	B4	B3	B2	B1	B0									
06h	R5	R4	R3	R2	R1	R0	X	X	X	X	X	X	X	X	X	X	262K-Color
	B5	B4	B3	B2	B1	B0	X	X	X	X	X	X	X	X	X		
	G5	G4	G3	G2	G1	G0	X	X	X	X	X	X	X	X	X		



5.5 Power On/Off Sequence

5.5.1 Power On Sequence

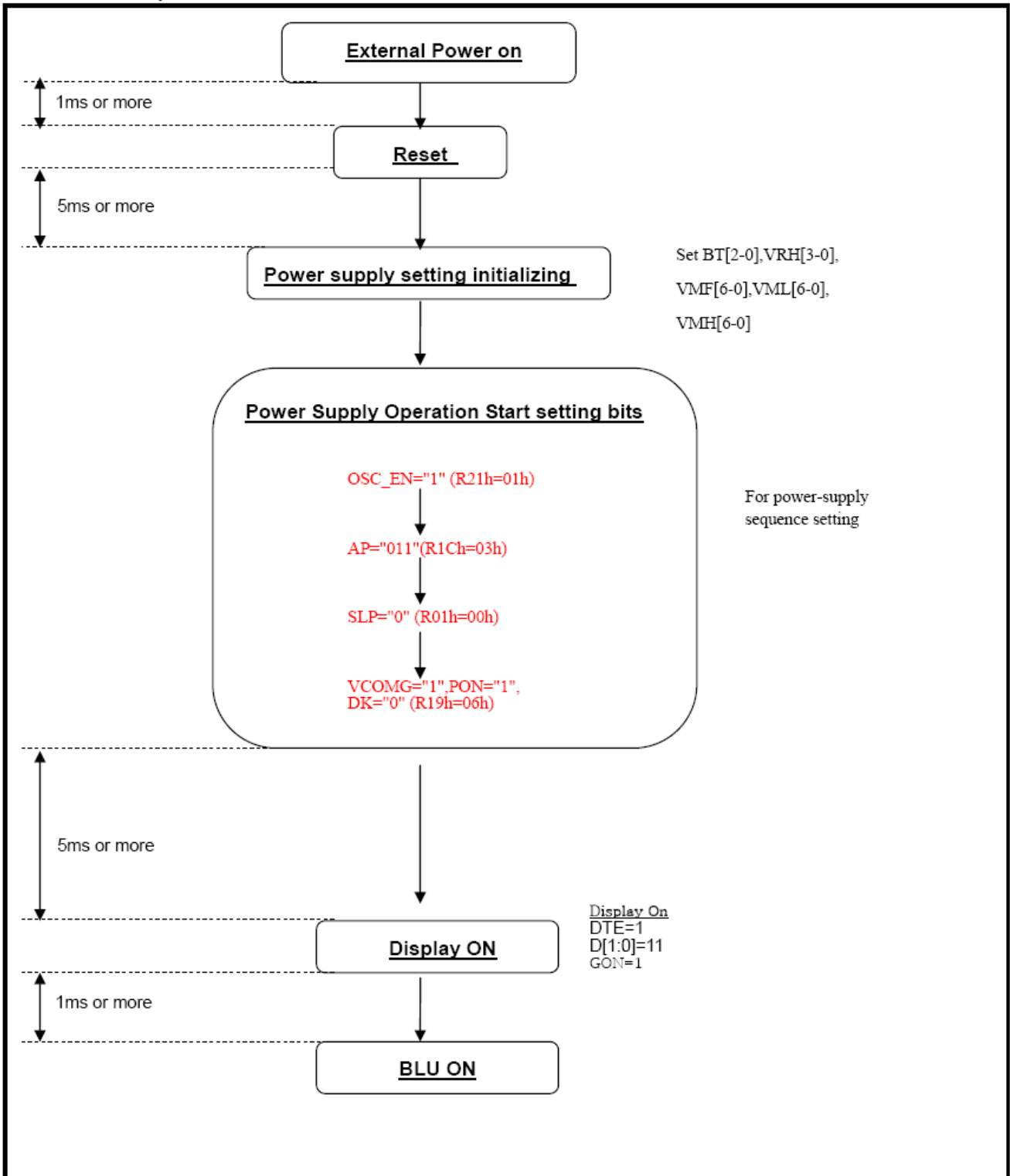



5.5.2 Power Off Sequence

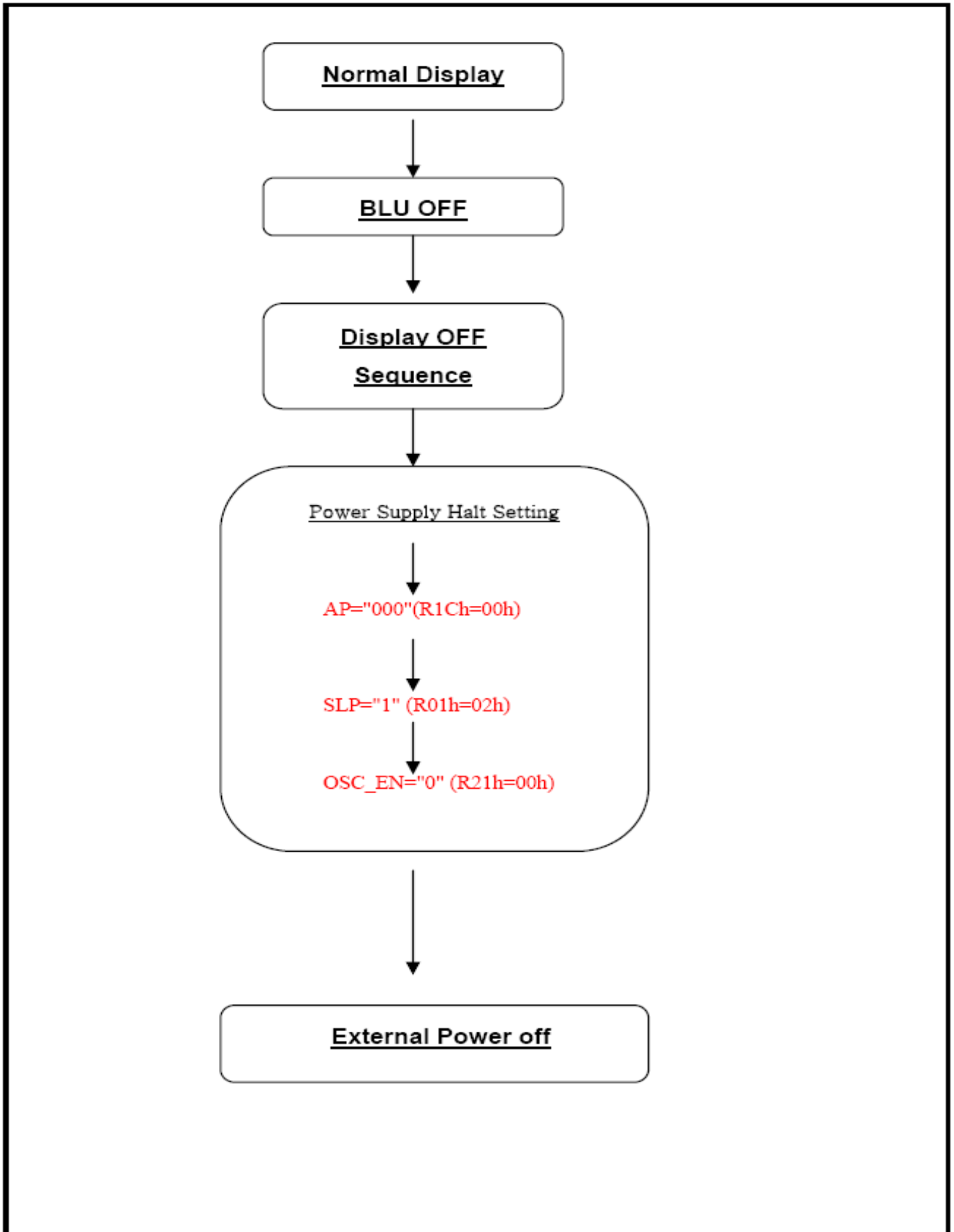



6 Optical Characteristics

6.1 Optical Specification

Ta=25°C

Item	Symbol	Condition	Min	Typ	Max	Unit	Remark	
View Angles	θT	$CR \geq 10$	50	60	--	Degree	Note 2	
	θB		45	55	--			
	θL		50	60	--			
	θR		50	60	--			
Contrast Ratio	CR	$\theta=0^\circ$	400	500	--		Note1 Note3	
Response Time	T_{ON}	25°C	--	25	40	ms	Note1	
	T_{OFF}						Note4	
Chromaticity	White	Backlight is on	x	0.234	0.284	0.334		Note5 Note1
			y	0.262	0.312	0.362		
	Red		x	0.561	0.611	0.661		
			y	0.288	0.338	0.388		
	Green		x	0.274	0.324	0.374		
			y	0.562	0.612	0.662		
	Blue		x	0.095	0.145	0.195		
			y	0.041	0.091	0.141		
Uniformity	U		75	80	--	%	Note1 Note6	
NTSC			55	60	--	%	Note 5	
Luminance	L		200	220	--	cd/m ²	Note1 Note7	

Test Conditions:

1. $V_F = 3.2V$, $I_F = 15mA$ (LED current), the ambient temperature is 25°C.
2. The test systems refer to Note 1 and Note 2.



Note 1: Definition of optical measurement system.

The optical characteristics should be measured in dark room. After 5 minutes operation, the optical properties are measured at the center point of the LCD screen. All input terminals LCD panel must be ground when measuring the center area of the panel.

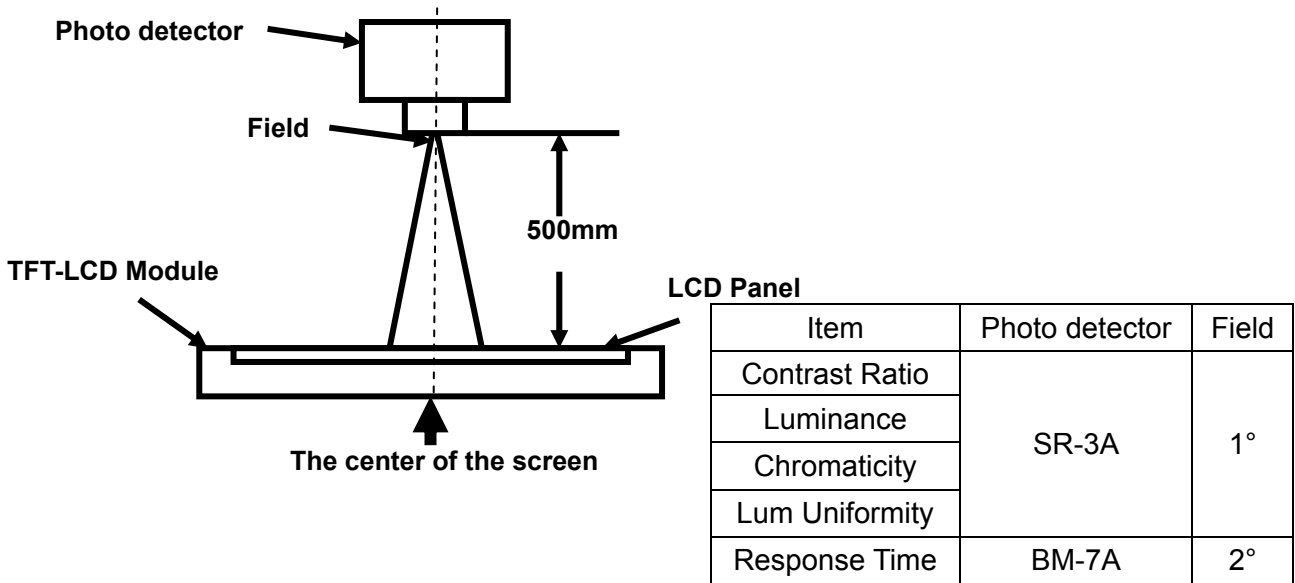

Note 2: Definition of viewing angle range and measurement system.

viewing angle is measured at the center point of the LCD by CONOSCOPE(ergo-80).

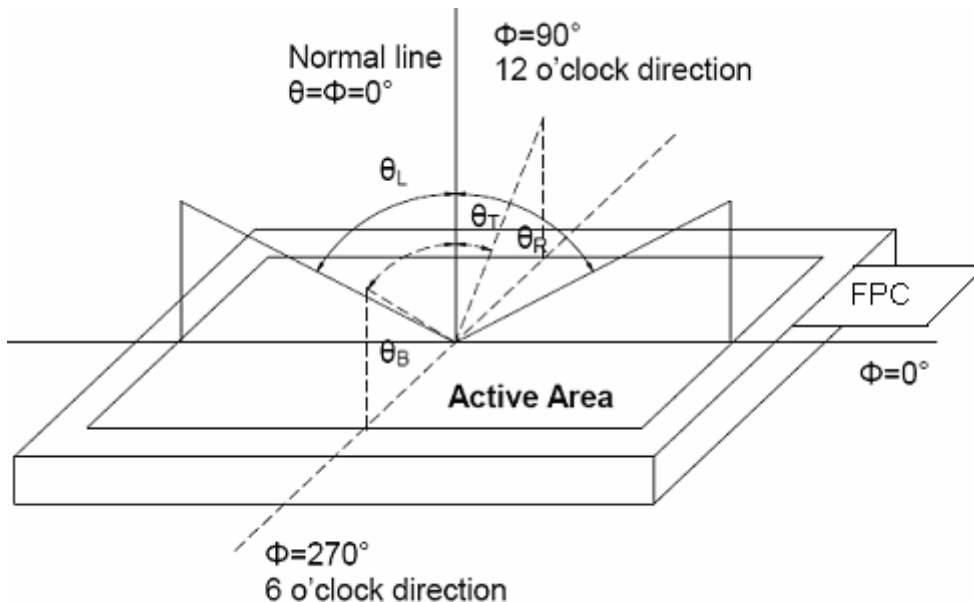

Fig. 1 Definition of viewing angle



Note 3: Definition of contrast ratio

$$\text{Contrast ratio (CR)} = \frac{\text{Luminance measured when LCD is on the "White" state}}{\text{Luminance measured when LCD is on the "Black" state}}$$

“White state “:The state is that the LCD should driven by V_{white} .

“Black state”: The state is that the LCD should driven by V_{black} .

V_{white} : To be determined V_{black} : To be determined.

Note 4: Definition of Response time

The response time is defined as the LCD optical switching time interval between “White” state and “Black” state. Rise time (T_{ON}) is the time between photo detector output intensity changed from 90% to 10%. And fall time (T_{OFF}) is the time between photo detector output intensity changed from 10% to 90%.

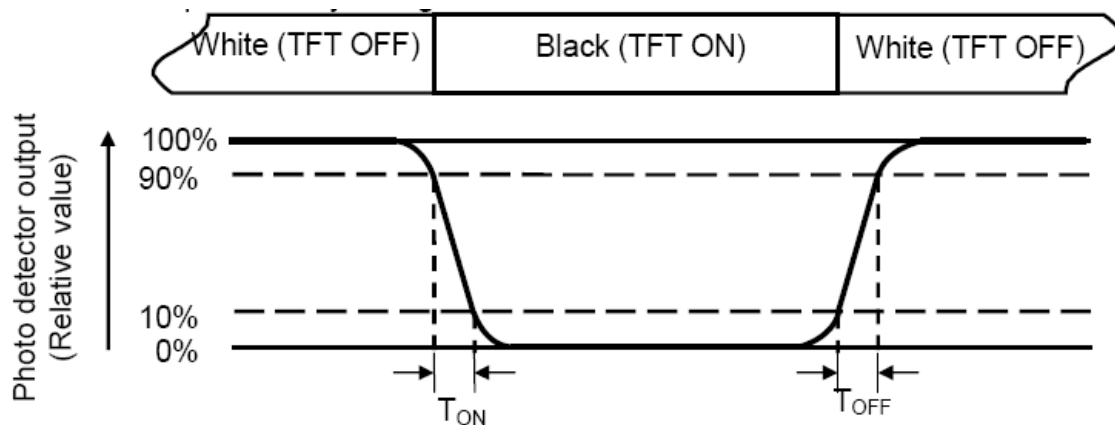

Note 5: Definition of color chromaticity (CIE1931)

Color coordinates measured at center point of LCD.



Note 6: Definition of Luminance Uniformity

Active area is divided into 9 measuring areas (Refer Fig. 2). Every measuring point is placed at the center of each measuring area.

$$\text{Luminance Uniformity}(U) = L_{\min} / L_{\max}$$

L-----Active area length W----- Active area width

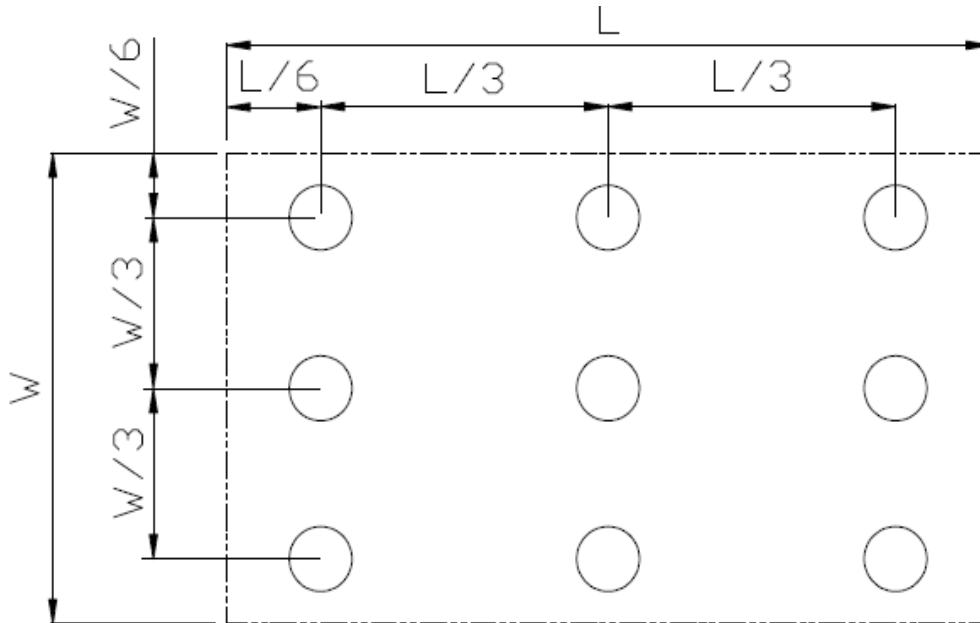

Fig. 2 Definition of uniformity

Lmax: The measured maximum luminance of all measurement position.

Lmin: The measured minimum luminance of all measurement position.

Note 7: Definition of Luminance :

Measure the luminance of white state at center point.



7 Environmental / Reliability Test

No	Test Item	Condition	Remark
1	High Temperature Operation	Ts=+70℃,240hrs	Note1 IEC60068-2-2,GB2423.2—89
2	Low Temperature Operation	Ta=-20℃,240hrs	IEC60068-2-1 GB2423.1—89
3	High Temperature Storage	Ta=+80℃,240hrs	IEC60068-2-2, GB2423.2—89
4	Low Temperature Storage	Ta=-30℃,240hrs	IEC60068-2-1 GB2423.1—89
5	High Temperature & High Humidity Storage	Ta=+60℃,90% RH 240 hours.	Note2 IEC60068-2-3, GB/T2423.3—2006
6	Thermal Shock (Non-Operation)	-30℃ 30 min~+80℃ 30 min, Change time:5min, 20 Cycles	Start with cold temperature, End with high temperature, IEC60068-2-14,GB2423.22—87
7	Electro Static Discharge (Operation)	C=150pF, R=330Ω, oints/panel Air:±8KV, 5times; Contact:±4KV, 5 times; (Environment: 15℃~35℃, 30%~60%, 86Kpa~106Kpa)	IEC61000-4-2 GB/T17626.2—1998
8	Vibration (Non-Operation)	Frequency range:10~55Hz, Stroke:1.5mm Sweep:10Hz~55Hz~10Hz 2 hours for each direction of X.Y.Z. (6 hours for total) (Package condition)	IEC60068-2-6 GB/T2423.10—1995
9	Shock (Non-Operation)	60G 6ms, ±X,±Y,±Z 3times, for each direction	IEC60068-2-27 GB/T2423.5—1995
10	Package Drop Test	Height:80 cm, 1 corner, 3 edges, 6 surfaces	IEC60068-2-32 GB/T2423.8—1995

Note1: Ts is the temperature of panel's surface.

Note2: Ta is the ambient temperature of samples.



8 Mechanical Drawing

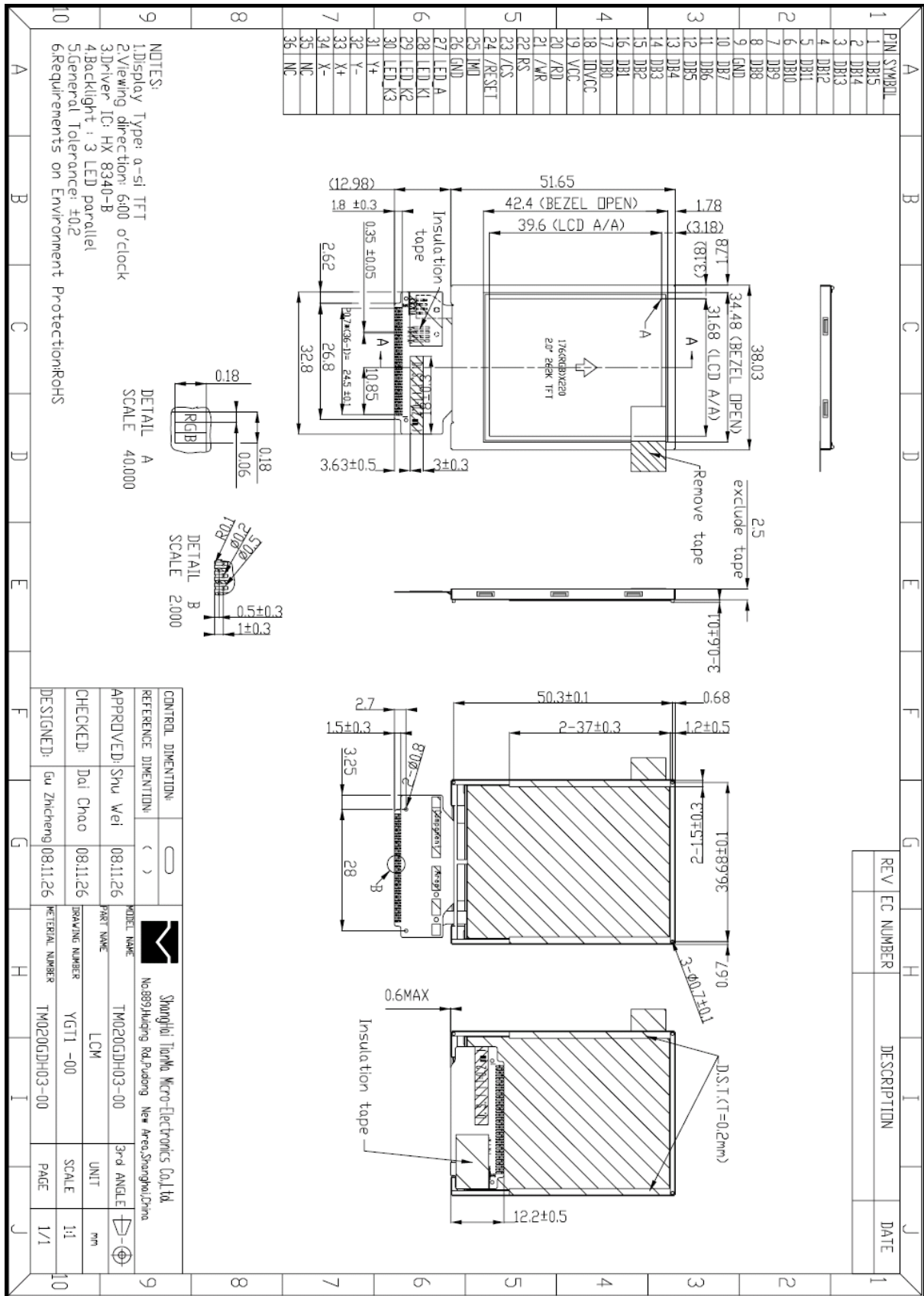

CONTROL DIMENTION	
REFERENCE DIMENTION	
APPROVED: Shu Wei	08.11.26
CHECKED: Dai Chao	08.11.26
DESIGNED: Gu Zhicheng	08.11.26
MODEL NAME: TM020GDH03-00	
PART NAME: LCM	
DRAWING NUMBER: YGT1-00	
MATERIAL NUMBER: TM020GDH03-00	
Shanghai Tianma Micro-Electronics Co., Ltd.	
No.899 Huoding Rd., Pudong New Area, Shanghai, China	
UNIT	mm
SCALE	1:1
PAGE	1/1

REV	EC NUMBER	DESCRIPTION	DATE

The information contained herein is the exclusive property of SHANGHAI TIANMA MICRO-ELECTRONICS Corporation, and shall not be distributed, reproduced, or disclosed in whole or in part without prior written permission of SHANGHAI TIANMA MICRO-ELECTRONICS Corporation.



9 Packing Drawing

Packaging Material Table

No	Item	Model (Material)	Dimensions(mm)	Unit Weight (Kg)	Quantity	Remark	
1	LCM Module	TM020GDH03	38.03×51.65×2.5	0.008	432		
2	Tray	PET(Transmit)	315×247×11	0.086	42	Anti-Static	
3	EPE	EPE	315×247×5	0.08	12		
4	Dust-Proof Bag	PE	700×545	0.05	1		
5	Anti-Static Bag	PE	327×270	0.01	6		
6	Box	Corrugate Paper	345×260×70	0.44	6		
7	Carton	Corrugated Paper	544×365×250	1.01	1		
8	Total Weight(Kg)	(11.8±0.6)Kg					

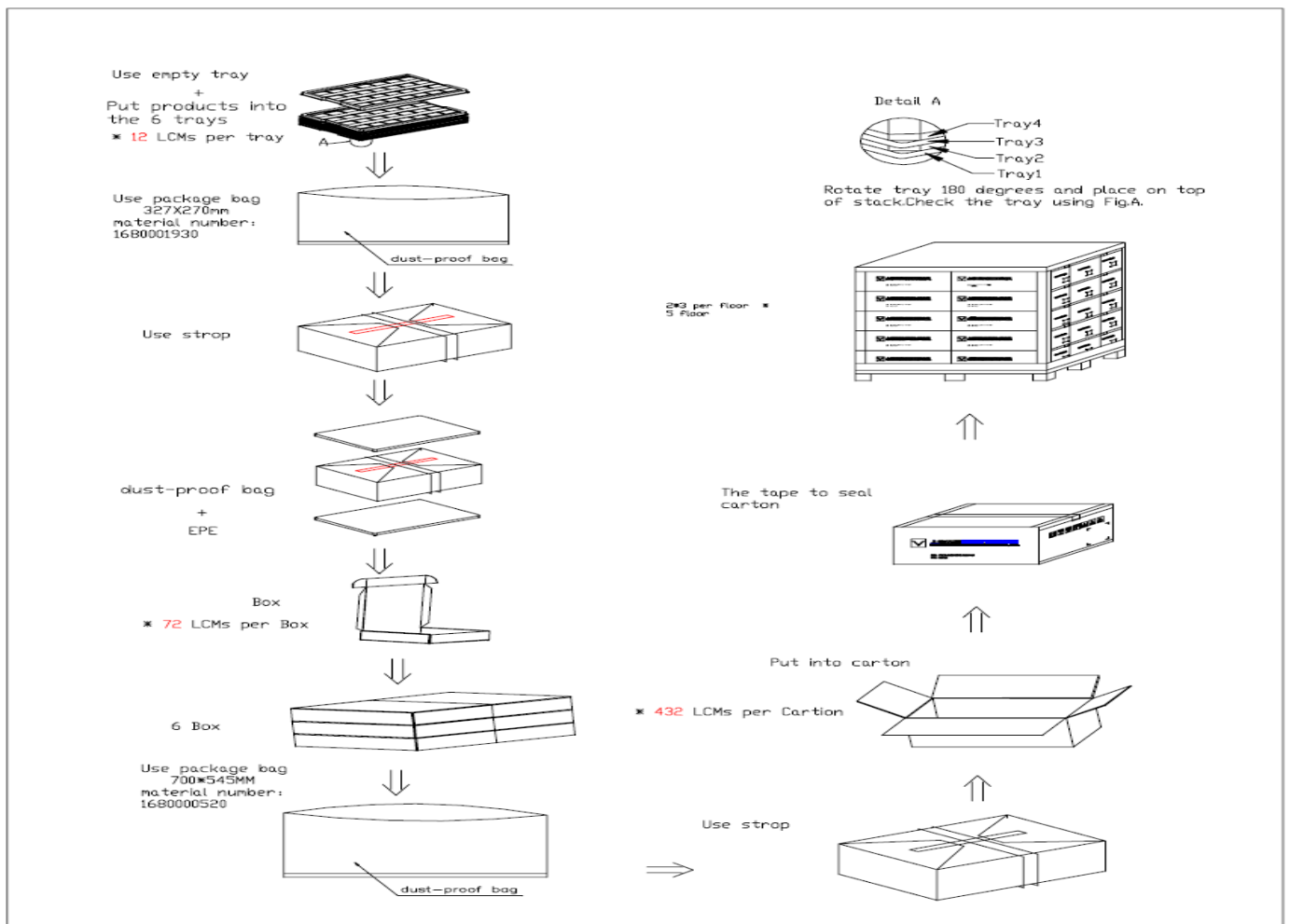

The information contained herein is the exclusive property of SHANGHAI TIANMA MICRO-ELECTRONICS Corporation, and shall not be distributed, reproduced, or disclosed in whole or in part without prior written permission of SHANGHAI TIANMA MICRO-ELECTRONICS Corporation.



10 Precautions For Use of LCD Modules

10.1 Handling Precautions

The display panel is made of glass. Do not subject it to a mechanical shock by dropping it from a high place, etc.

10.1.1 If the display panel is damaged and the liquid crystal substance inside it leaks out, be sure not to get any in your mouth, if the substance comes into contact with your skin or clothes, promptly wash it off using soap and water.

10.1.2 Do not apply excessive force to the display surface or the adjoining areas since this may cause the color tone to vary.

10.1.3 The polarizer covering the display surface of the LCD module is soft and easily scratched. Handle this polarizer carefully.

10.1.4 If the display surface is contaminated, breathe on the surface and gently wipe it with a soft dry cloth. If still not completely clear, moisten cloth with one of the following solvents:

- Isopropyl alcohol
- Ethyl alcohol

Solvents other than those mentioned above may damage the polarizer. Especially, do not use the following:

- Water
- Ketone
- Aromatic solvents

10.1.5 Do not attempt to disassemble the LCD Module.

10.1.6 If the logic circuit power is off, do not apply the input signals.

10.1.7 To prevent destruction of the elements by static electricity, be careful to maintain an optimum work environment.

10.1.7.1 Be sure to ground the body when handling the LCD Modules.

10.1.7.2 Tools required for assembly, such as soldering irons, must be properly ground.

10.1.7.3 To reduce the amount of static electricity generated, do not conduct assembly and other work under dry conditions.

10.1.7.4 The LCD Module is coated with a film to protect the display surface. Be care when peeling off this protective film since static electricity may be generated.

10.2 Storage Precautions

10.2.1 When storing the LCD modules, avoid exposure to direct sunlight or to the light of fluorescent lamps.

10.2.2 The LCD modules should be stored under the storage temperature range. If the LCD modules will be stored for a long time, the recommend condition is:

Temperature : 0°C ~ 40°C Relatively humidity: ≤80%

10.2.3 The LCD modules should be stored in the room without acid, alkali and harmful gas.

10.3 Transportation Precautions

The LCD modules should be no falling and violent shocking during transportation, and also should avoid excessive press, water, damp and sunshine.